

Presentation to Canterbury Active Transport Forum
Tuesday 2 December 2008

MOTSAM Amendments

Axel Wilke

ViaStrada Ltd, Christchurch

Stanley Chesterfield

NZTA head office, Wellington

www.viastrada.co.nz



Outline

- MOTSAM – what is it
- Why update
- What's new
- Intersection continuity
- Other new traffic control devices
- Process
- Relationship to NZ Supplement
- More information



MOTSAM – what is it?

- Manual of Traffic Signs and Markings
 - Used by NZ traffic and roading engineers
 - Markings part gives guidelines for laying out road markings

VIASTRADA

MANUAL
OF
TRAFFIC SIGNS
AND
MARKINGS
PART II - MARKINGS

Update July 2008

Part I: ISBN 0 - 478 - 04112 - 8
(Part II: ISBN 0 - 478 - 04116 - 0)

TRANSIT NEW ZEALAND
P O Box 4994
Wellington
Phone: (04) 499 6600
Fax: (04) 499 6666

LAND TRANSPORT NEW ZEALAND
P O Box 2840
Wellington
Phone: (04) 931 8700
Fax: (04) 931 8708

Why update

- Cycling part seriously outdated
- Only one intersection layout
 - Approach to T intersection
 - Kilmarnock Street approach Deans Avenue (1970s)
 - 2001 actual layout upgraded to 'best engineering practice'
 - 2008 MOTSAM still encouraged discontinuity

VIASTRADA

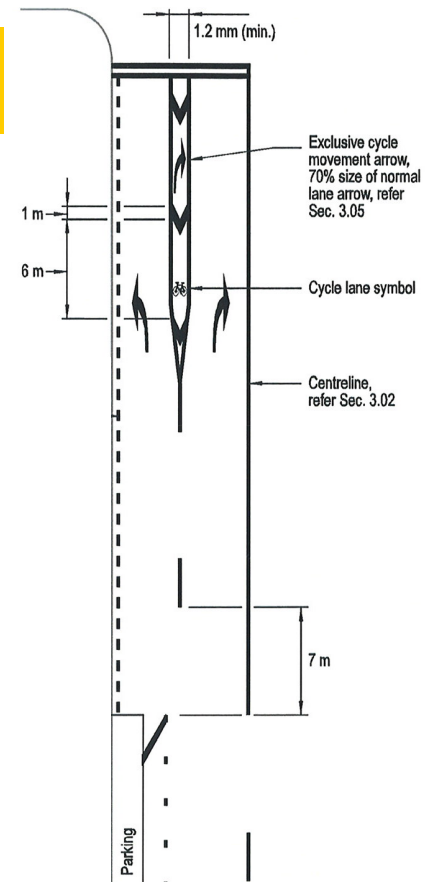

Scope

- ViaStrada updated markings part
 - Part 2 – Pavement Markings
 - Part 3 – Intersection Markings
 - Part 4 – Miscellaneous Pavement Markings

VIASTRADA

What's new

- Facility continuity
 - On approach to signals
 - Across side street
- Advanced Stop Lines
- Advanced Stop Boxes
- Coloured surfaces
- Hook turns
- Solid cycle lane lines



VIASTRADA

Six Elements of Continuity

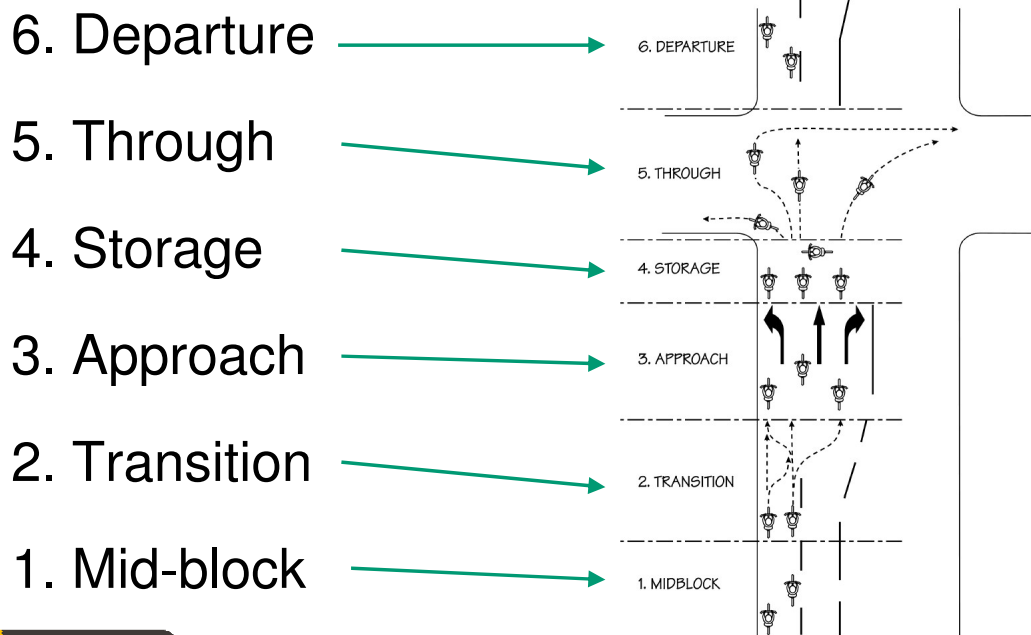

VIASTRADA

Continuity

- Continuity on the approach to intersections
 - Additional lanes form – motorists weaving
 - Continuous lanes guide cyclists
 - Encourages predictable cycle behaviour
 - Motorists can better predict what cyclists are doing
- Continuity also across side streets
- Colour recommended for these areas

VIASTRADA

Continuity cont'd

- Continuity across lane diverge now given

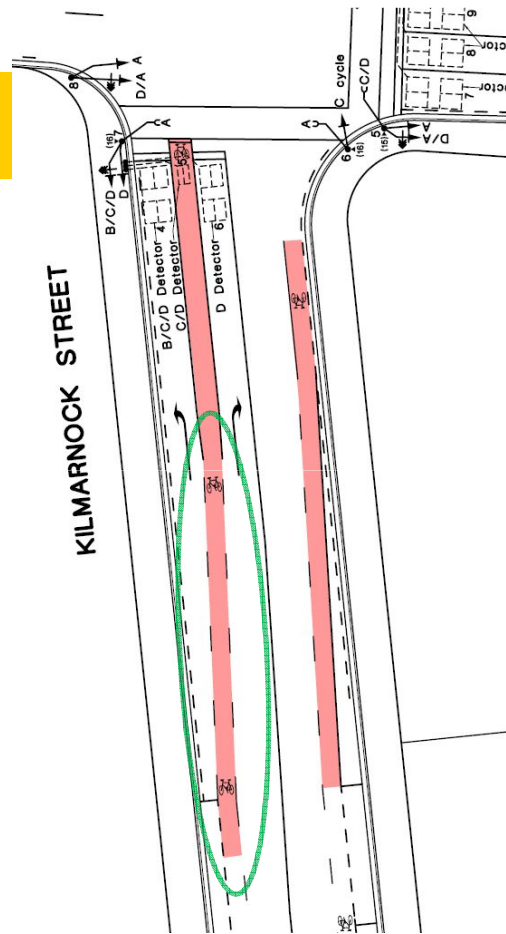
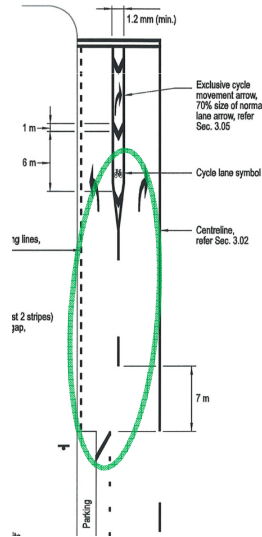

Advanced Stop Line

- Cycle lane stops closer to intersection than adjacent traffic lane(s)
- Increases visibility of cyclists to drivers
 - Especially truckies
- Should be standard cycle lane treatment at every signalised intersection

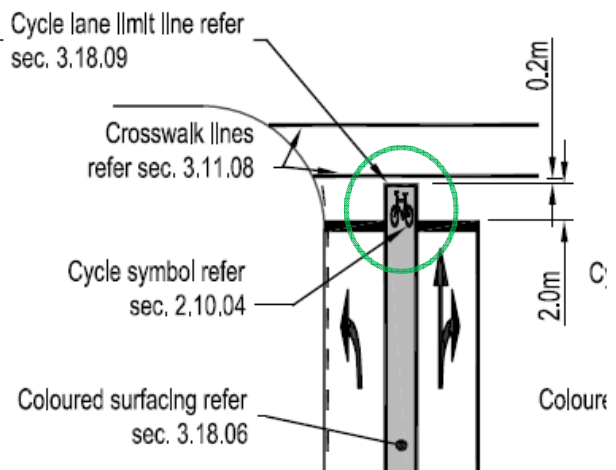

Advanced Stop Line



Advanced Stop Box

- Waiting area in front of a traffic lane
 - With or without lead in cycle lane
- ASBs have advantages and disadvantages
- Use with caution

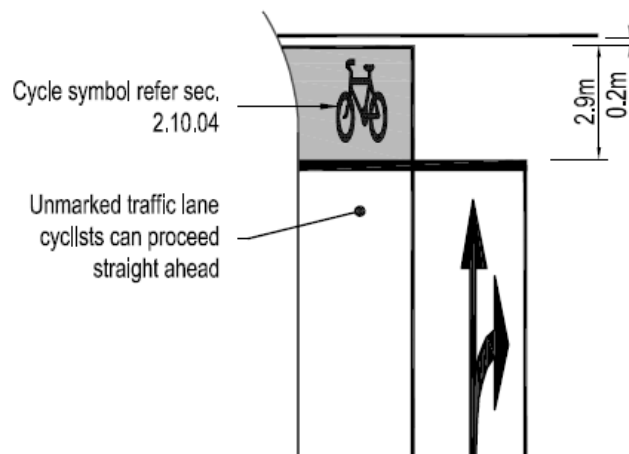

Rule Broken – Why?



VIASTI

Advanced Stop Box Layout

- Recommended and inappropriate usage shown

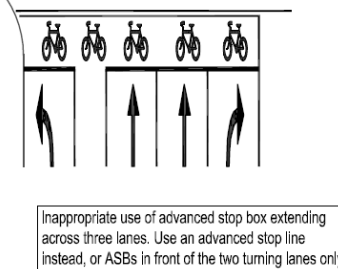
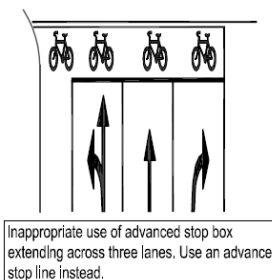
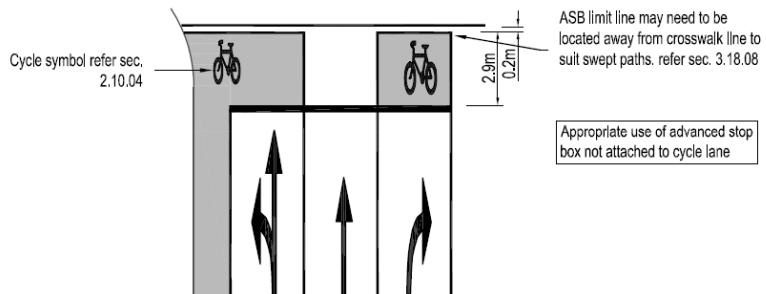

VIASTRADA

Use of Colour

- Colour to be used in ‘stress points’
 - In rare occasions, can also guide cyclists
- Green is recommended for cycle facilities in NZ
 - Sorry, Christchurch CC and Waimak DC
 - Remember it’s a guideline though
- Colour history

<http://viastrada.co.nz/pub/1999-tmw>

VIASTRADA



Process for Updating

- Draft content
- Invited selected industry stakeholders to give feedback
 - Commendable effort
- Feedback got reviewed
- Worked in feedback
 - NZTA & ViaStrada
- Finalised material and published (Aug 08)

* where there is low parking demand and a cycle route
- suggest breaking the continuous white line with
cycle symbols at appropriate intervals to remind
motorists of the need to leave space for cyclists



VIASTRADA

Relationship to NZ Supplement

- NZ Supplement to Austroads Part 14 is referenced in MOTSAM
 - Supplement content not repeated, but referred to
 - Hence Supplement can be amended without also having to amend MOTSAM
- NZ Supplement in itself got updated in 2008
 - Significant ViaStrada input

VIASTRADA

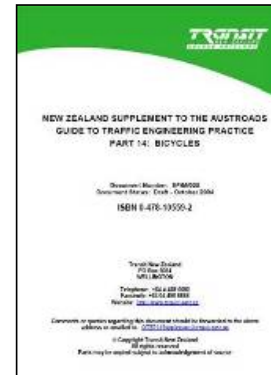

More information

- MOTSAM Update Notice
<http://viastrada.co.nz/news/2008/motsam-update-published>
- NZ Supplement Amendments
<http://viastrada.co.nz/news/2008/nz-supplement-further-amended>
- ViaStrada newsletter
<http://viastrada.co.nz> to subscribe
- Stanley Chesterfield (NZTA)
Phone (04) 496 6695
- Axel Wilke (ViaStrada)
Phone (03) 343 8221

VIASTRADA



Thank you

- Any questions?



VIASTRADA